

SAE J 518 C 61/62 Flanges

SAE - welding head

SASFH - BW

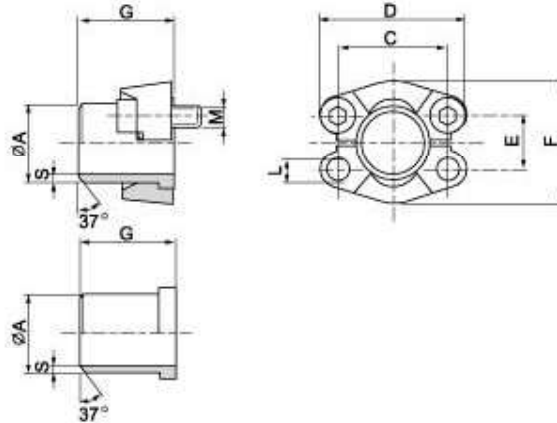

Maximum recommended working pressure kg/cm ²	Nominal flange size, in	Type	Dimensions							Screws		Weight kg
			Pipe size A x S	C	D	E	F	G	L	M		
										metr.	unc	
Standard Pressure												
350	½"	SASFS 308-08 BW	21.3 x 3.7	38.10	54	17.48	45.6	41	9.0	M 8 x 25	⅝ x 1½	0.08
350	¾"	SASFS 312-12 BW	26.7 x 3.9	47.63	65	22.23	51.8	50	11.0	M 10 x 30	⅝ x 1½	0.16
350	1"	SASFS 316-16 BW	33.4 x 4.5	52.37	70	26.19	58.4	50	11.0	M 10 x 30	⅝ x 1½	0.23
280	1½"	SASFS 320-20 BW	42.2 x 4.9	58.72	79	30.18	72.6	55	11.5	M 10 x 30	⅝ x 1½	0.30
210	1½"	SASFS 324-24 BW	48.3 x 5.1	69.85	94	35.71	82.2	57	13.5	M 12 x 35	⅝ x 1½	0.40
210	2"	SASFS 332-32 BW	60.3 x 5.5	77.77	102	42.88	96.4	57	13.5	M 12 x 35	⅝ x 1½	0.50
175	2½"	SASFS 340-40 BW	73.0 x 7.0	88.90	114	50.80	108.2	58	13.5	M 12 x 40	⅝ x 1½	0.80
140	3"	SASFS 348-48 BW	88.9 x 7.6	106.38	135	61.93	130.6	58	17.0	M 16 x 45	⅝ x 2	1.10
35	3½"	SASFS 356-56 BW	101.5 x 8.1	120.65	152	69.85	139.0	60	17.0	M 16 x 45	⅝ x 2	1.40
35	4"	SASFS 364-64 BW	114.3 x 8.6	130.18	162	77.77	152.0	60	17.0	M 16 x 50	⅝ x 2	1.75
35	5"	SASFS 380-80 BW	141.3 x 9.5	152.40	184	92.08	180.0	60	17.0	M 16 x 50	⅝ x 2	2.62
High Pressure												
420	½"	SASFS 608-08 BW	21.3 x 4.7	40.49	56	18.24	47.2	34	9.0	M 8 x 30	⅝ x 1½	0.08
420	¾"	SASFS 612-12 BW	26.7 x 5.5	50.80	71	23.80	60.0	38	11.0	M 10 x 35	⅝ x 1½	0.17
420	1"	SASFS 616-16 BW	33.4 x 6.4	57.15	81	27.76	69.6	40	12.5	M 12 x 45	⅝ x 1½	0.25
420	1½"	SASFS 620-20 BW	42.2 x 6.4	66.68	95	31.75	77.2	45	14.5	M 14 x 50	⅝ x 1½	0.30
420	1½"	SASFS 624-24 BW	48.3 x 7.1	79.38	113	36.50	95.0	50	17.0	M 16 x 55	⅝ x 2	0.53
420	2"	SASFS 632-32 BW	60.3 x 8.7	96.82	133	44.45	113.8	58	21.0	M 20 x 65	⅝ x 2½	0.90
420	2½"	SASFS 640-40 BW	73.0 x 9.5	123.80	180	58.80	150.2	75	26.0	M 24 x 75	-	2.40
420	3"	SASFS 648-48 BW	88.9 x 11.1	152.40	215	71.60	198.2	80	31.0	M 30 x 90	-	3.60